

ANNEX 15

**RESOLUTION MSC.378(93)
(adopted on 22 May 2014)**

**AMENDMENTS TO THE REVISED RECOMMENDATION ON TESTING
OF LIFE-SAVING APPLIANCES (RESOLUTION MSC.81(70), AS AMENDED)**

THE MARITIME SAFETY COMMITTEE,

RECALLING Article 28(b) of the Convention on the International Maritime Organization concerning the functions of the Committee,

RECALLING ALSO resolution A.689(17) entitled *Testing of life-saving appliances*, by which the Assembly, at its seventeenth session, adopted the *Recommendation on testing of life-saving appliances*,

RECALLING FURTHER that the Assembly, when adopting resolution A.689(17), authorized the Committee to keep the *Recommendation on testing of life-saving appliances* under review and to adopt, when appropriate, amendments thereto,

NOTING resolution MSC.81(70), by which, at its seventieth session, it adopted the *Revised recommendation on testing of life-saving appliances*, introducing more precise provisions for the testing of life-saving appliances based on the requirements of the International Life-Saving Appliances (LSA) Code,

RECOGNIZING the need to appropriately align the relevant provisions of the *Revised recommendation on testing of life-saving appliances* with the associated amendments to the LSA Code adopted by resolution MSC.320(89),

HAVING CONSIDERED, at its ninety-third session, proposed amendments to the *Revised recommendation on testing of life-saving appliances*, prepared by the Sub-Committee on Ship Design and Equipment at its fifty-seventh session,

1 ADOPTS amendments to the *Revised recommendation on testing of life-saving appliances* (resolution MSC.81(70)), the text of which is set out in the annex to the present resolution;

2 RECOMMENDS Governments to apply the annexed amendments when testing life-saving appliances.

ANNEX

**AMENDMENTS TO THE REVISED RECOMMENDATION ON TESTING
OF LIFE-SAVING APPLIANCES (RESOLUTION MSC.81(70), AS AMENDED)**

Part 1 – Prototype tests for life-saving appliances

Section 2 – Lifejackets

- 1 In paragraph 2.6, the first sentence is replaced with the following:

"The tests specified in 2.6.1 to 2.6.7 should be carried out on eight specimens of each lifejacket-buoyancy material. A further four specimens of each lifejacket-buoyancy material should be prepared for the test specified in 2.6.8."
- 2 Paragraph 2.7.2.3 is amended to read as follows:

".3 at least one male should be from the lowest and highest weight group and one female should be from the lowest weight group and one female should be more than 80 kg and 1.8 m;"
- 3 The following sentence is added at the end of paragraph 2.8.1:

"Each test for a candidate lifejacket and the relevant RTD should be conducted on the same day."
- 4 In paragraph 2.8.4, the following sentence is added after the second sentence:

"Prior to taking the measurements in 2.8 and 2.9, the proper fit, donning, and fastening of the RTD on the subject should be checked and corrected as necessary."
- 5 In paragraph 2.8.7.1, the words "plus 1 s" are added after the words "the average time in the RTD".
- 6 In paragraph 2.8.7.2, the words "minus 10 mm" are added at the end.
- 7 In paragraph 2.8.7.3, the words "minus 5°" are replaced with the words "minus 10°".
- 8 In paragraph 2.8.7.4, the word "(head)" is deleted and the words "minus 5°" are replaced with the words "minus 10°".
- 9 Paragraph 2.8.9.1 is amended to read as follows:

".1 surface the test subject in a face up position with an average freeboard for all the subjects of not less than the average determined for the RTD after the turning test in accordance with 2.8.6 minus 15 mm;"
- 10 The following sentence is added at the end of paragraph 2.9:

"The tests may be modified for child test subjects under 12 years of age who are not comfortable in water, so as to ensure their safety and cooperation."
- 11 In paragraph 2.9.1.5, the words "infant lifejacket" are deleted.
- 12 In paragraph 2.9.2.1, the words "plus 1 s" are added at the end.

13 In paragraph 2.9.2.2, the words "minus 10 mm" are added at the end.

14 In paragraph 2.9.2.4, the word "(head)" is deleted.

15 The chapeau of paragraph 2.9.3 is replaced with the following:

"Infant lifejackets should meet the requirements of 2.9.2.1 and 2.9.2.2, however, the requirements for torso angle, faceplane and mobility may be relaxed if necessary in order to:"

APPENDIX 1

Adult reference test device (RTD) design and construction

16 Appendix 1 is replaced with the following:

"1 GENERAL

The RTD is intended for use only as a test reference standard to represent the desired level of in-water performance of a lifejacket required by the Convention, and is not considered representative of any other required lifejacket performance. The adult RTD is designed to fit persons from a chest size of 700 mm to 1350 mm and to be comfortable to wear as a non-reversible device such that it would be obvious to the wearer as to which is the inside and outside of the device, even under reduced lighting conditions. The adult RTD is made with two types of buoyant foam in a vest style using a heavy nylon cover fabric shell secured to the body with 25 mm webbing, closures and adjustments. The shell is made with slide fasteners (zippers) in place of closing seams to hold the foam within, in order that the foam inserts can be easily removed to check their buoyancy and renew or supplement them if they are out of tolerance. Hook and loop fasteners are used on the interior foam retainers to position and prevent shifting of the foam panels.

2 MATERIALS

All materials used should comply with ISO 12402-7:2006.

2.1 Foam requirements

The performance of the RTD is dependent on using plastic foam of the proper stiffness, shape and buoyancy.

2.1.1 *Stiffness*

Two different stiffness foams are used: one is a soft foam and the other is a stiff foam. A bridge deflection test is provided to determine acceptability for the intended application. Figure A.20 provides the setup details and table A.1 provides the specific measured values. For selecting the type of foam for the specific insert, see tables A.2 and A.3. To measure the centre deflection of a foam panel of the specified cross-section ($a \times b$) and 110 mm wide, place the foam panel centred across the two equal height, parallel horizontal surfaces separated by the specified distance (c), and then load with a mass of the specified width. Note the length of the load should be at least 110 mm, such that when placed on the foam panel it will extend the full width of the foam panel. It is acceptable for the load to extend beyond the width of the foam panel provided that it is centred over the panel with equal amounts extending over the sides of the foam panel. Measure the deflection at the bottom centre location of the foam panel 30 s after placing the load on the panel.

2.1.2 Shape

The shape of each foam insert is specified in figures A.27 to A.30. For dimensions see tables A.2 and A.4.

2.1.3 Buoyancy

The total design buoyancy of the foam inserts is 149 N. Table A.3 specifies the foam characteristics, the buoyancy for each insert and its tolerances and the overall buoyancy distribution to be verified with using the RTD for certification testing.

2.2 Other component requirements

See table A.2.

3 CONSTRUCTION

The construction and assembly of the device should be in accordance with tables A.2 to A.5, figures A.1 to A.19 and figures A.21 to A.36. A tolerance of ± 6 mm is used throughout for fabric cutting and stitching assembly. A tolerance of ± 6 mm is also used for foam cutting, however, the buoyancy requirements of table A.3 should be met.

3.1 Seams

3.1.1 The seam allowances are 13 mm, unless otherwise specified. All structural seams use a lock type stitch so that the seam will not unravel when a force is applied in the direction of the seam on any of the threads forming the stitch. Stitching should have a density of 7 to 12 stitches per 25 mm of stitch length. The box-X stitching on the webbing is 15 mm \times 18 mm, unless otherwise specified. The bar-tack stitching on the webbing is 15 mm \times 2 mm.

3.1.2 On the closing seam of the back section of the outer and inside cover, the cut ends of the fabric are turned under and stitched so that the fabric will not ravel. The cut ends of webbing should be heat-sealed.

3.1.3 Tabs on the ends of the waist belt are formed by turning under 40 mm of material twice and stitching 19 mm from the end of the folds with box-X or bar tack stitching.

3.1.4 The zippers are set to the fabric by turning under the raw edge of the fabric 13 mm, aligning the fold with the centre of the closed zipper, and topstitching through both layers of fabric and the zipper tape. The stitch line should be far enough from the zipper teeth or coil so as not to interfere with the operation of the zipper.

3.2 Assembling the fabric cover

The fabric cover is assembled as described below, with the dimensions described in figures A.31 through A.33 and table A.4.

3.2.1 *Assembling the inside cover*

3.2.1.1 Attach the interior fabric retainers for foam inserts 1 (component 1.7) to the "wrong" (interior) side on each lobe of the inside cover fabric (component 1.3).

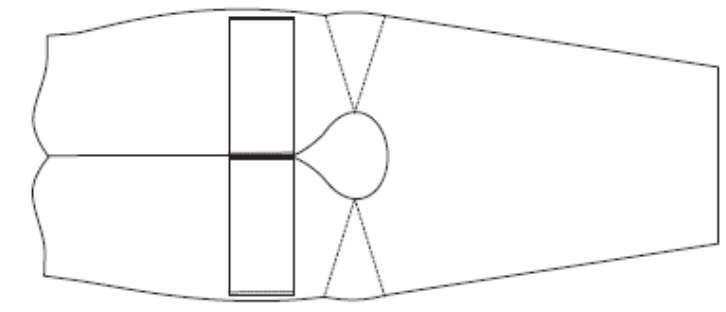

Figure A.1 – Location of Interior fabric retainers

3.2.1.2 Sew the hook and loop fasteners (component 4) to opposing sides of the interior fabric retainers for foam inserts 2 (component 1.8) as shown in figure A.2.

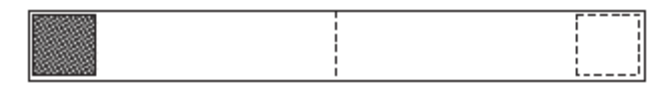

Figure A.2 – Orientation of hook and loop fasteners

3.2.1.3 Fold the interior fabric retainers for foam inserts 2 (component 1.8) in half and sew to the inside edge seam allowance of the "wrong" (interior) side of the inside cover fabric (component 1.3). Sew one fabric retainer to each lobe of the front cover fabric with the hook and loop fasteners (component 4) facing upward and oriented toward the outer edge of the inside cover fabric. Turn the bottom edge of the back cover up 13 mm and topstitch.

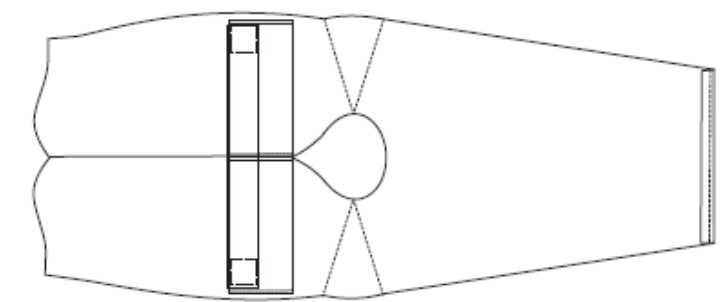

Figure A.3 – Location of fabric retainers

3.2.1.4 Attach one 89 mm black belt-loop webbing (component 3.5) to each lobe of the "right" (exterior) side of the inside cover fabric. Join the shoulder darts.

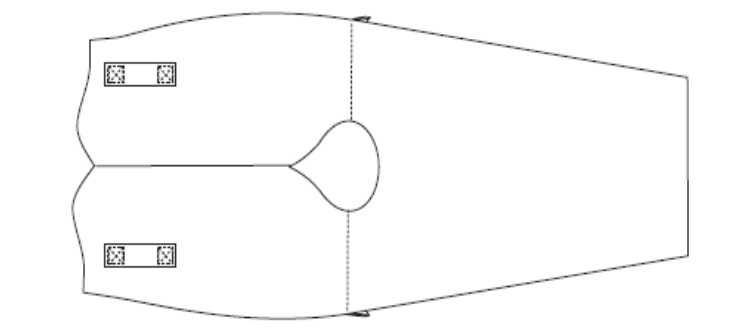

Figure A.4 – Completed inside cover

3.2.2 Assembling the collar cover

3.2.2.1 Attach the yellow collar attachment webbing (component 3.6) to the inside collar cover (component 1.5), placing one reinforcement patch (component 1.6) under the fabric, with a tack on each side, as in figure A.5. The webbing should be centred on the fabric, creating a 254 mm loop measured from the edge of one tack to the edge of the other.

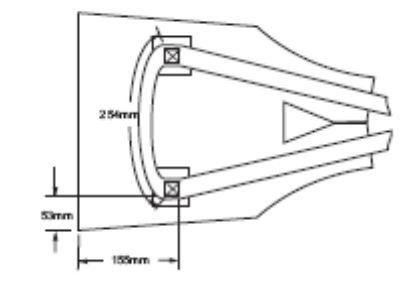

Figure A.5 – Collar attachment on collar cover

3.2.2.2 Sew the 280 mm zipper (component 6.5) to the inside and outer collar cover fabric (component 1.5) as in figure A.6.

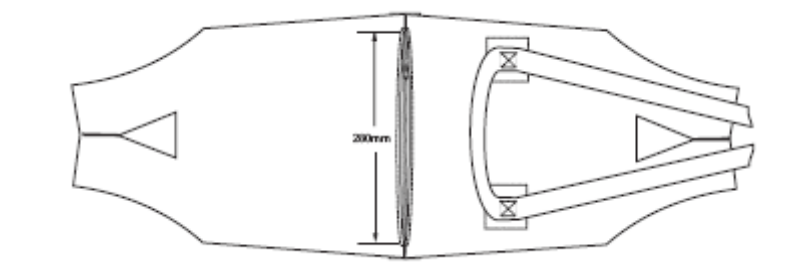

Figure A.6 – Joining the inside and outer collar cover

3.2.2.3 With the "right" (exterior) sides of the fabric together, join the sides of the inside and outer collar cover fabric (component 1.5) at the sides and around the neck opening. To allow access to the collar foam insert, do not join the fabric at the ends of the zipper. Turn the collar cover right side out.

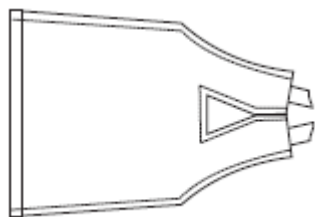

Figure A.7 – Completed collar cover

3.2.3 *Assembling the outer cover*

3.2.3.1 Attach one 76 mm black belt-loop webbing (component 3.4) to each shoulder on the "right" (exterior) side of the front outer cover fabric (component 1.1) using double bar tack stitches on each end, creating a 40 mm loop opening.

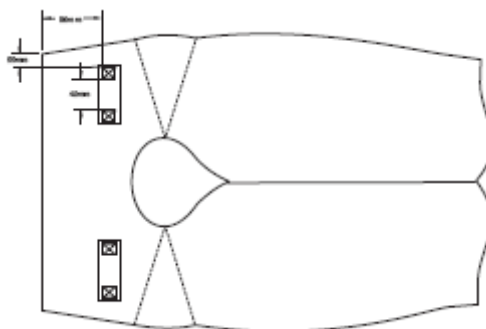

Figure A.8 – Attaching the shoulder loops

3.2.3.2 Sew the 370 mm zipper (component 6.6) to the back outer cover (component 1.2) and front outer cover (component 1.1) as shown in figure A.9. Turn the bottom edge of the back cover up 13 mm and topstitch.

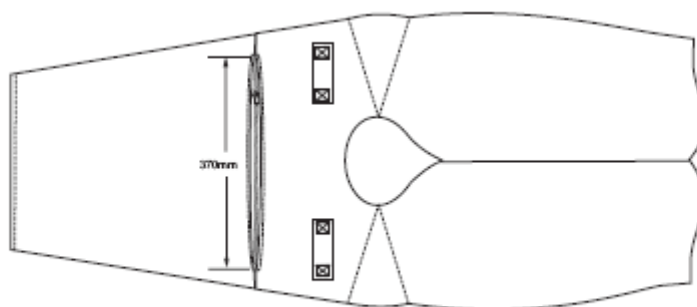

Figure A.9 – Completed outer cover

3.2.4 *Joining the collar to the front outer cover*

Join the shoulder darts on the front outer cover (component 1.1). Lace the yellow collar attachment webbing (component 3.6) through the black shoulder straps (component 3.4) with the collar loop facing toward the cover fabric. Stitch the collar cover fabric tabs to the neck seam.

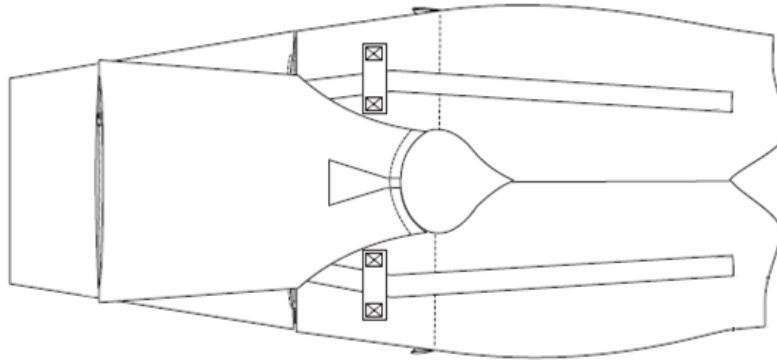
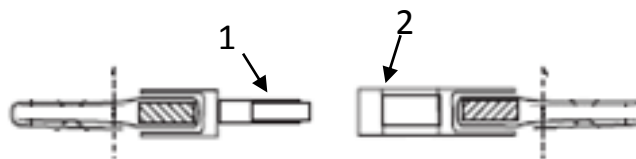

Figure A.10 – Joining the collar to the front outer cover

3.2.5 *Assembling and attaching the hardware assemblies*

3.2.5.1 Construct the chest strap buckle assemblies by lacing the 127 mm black chest strap webbing (component 3.1) through the male and female buckles (component 6.1) and stitching, as shown in figure A.11.



Key

- 1 Male buckle
- 2 Female buckle

Figure A.11 – Chest strap buckle assembly

3.2.5.2 Construct the waist belt assemblies by lacing the 203 mm black waist belt webbing (component 3.3) through the slide adjusters (component 6.2), snap hook (component 6.3), and D-ring (component 6.4), and stitching as shown in figure A.12.

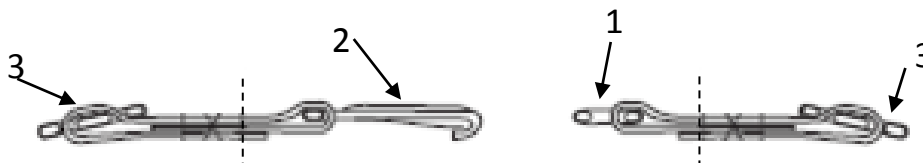

Key

- 1 D-Ring
- 2 Snap hook
- 3 Slide adjuster

Figure A.12 – Waist belt assembly

3.2.5.3 Lace the left side yellow collar attachment webbing (component 3.6) through the male chest strap buckle assembly. With one fabric reinforcement (component 1.6) positioned on the "wrong" (interior) side of the front outer cover fabric (component 1.1), attach the chest strap buckle assembly to the yellow collar attachment webbing and cover fabric with a box-X stitch. Repeat on the right side with the female chest strap buckle assembly.

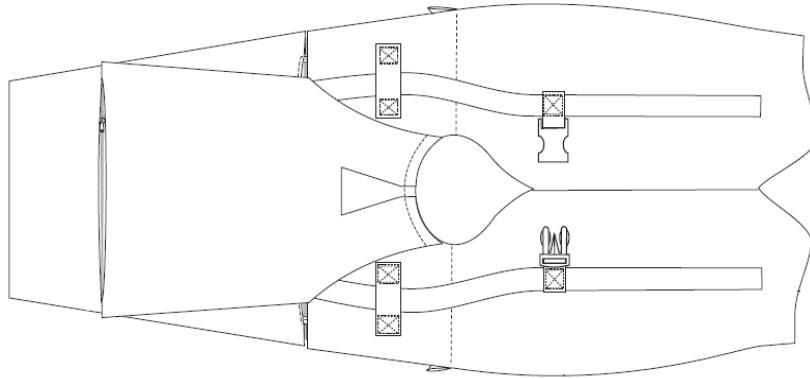

Figure A.13 – Attachment of chest strap buckle assembly

3.2.5.4 Lace the left side yellow collar attachment webbing (component 3.6) through the snap hook waist belt assembly. Attach the waist belt assembly to the yellow collar attachment webbing and the front outer cover fabric (component 1.1) with a box-X stitch. Repeat on the right side with the D-ring waist belt assembly.

3.2.5.5 Stitch the yellow collar attachment webbing to cover front, between the two buckle assemblies on each front forming a rectangle.

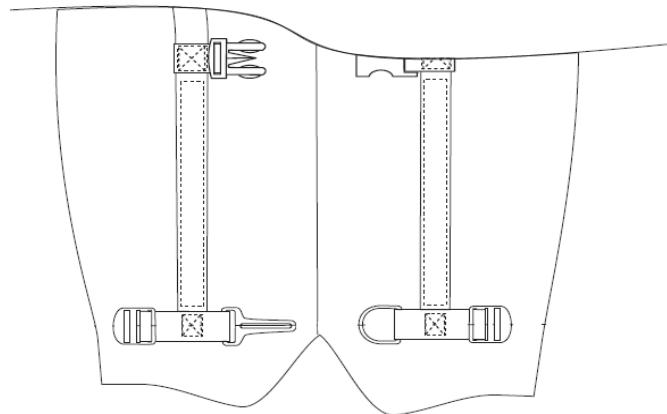

Figure A.14 – Chest and waist belt attachments

3.2.6 *Joining the inside and outer covers*

3.2.6.1 Join the inside cover fabric (component 1.3) to the front and back outer cover fabric (components 1.1 and 1.2) at the sides by sewing a 440 mm zipper (component 6.7) on the outside edge of each front.

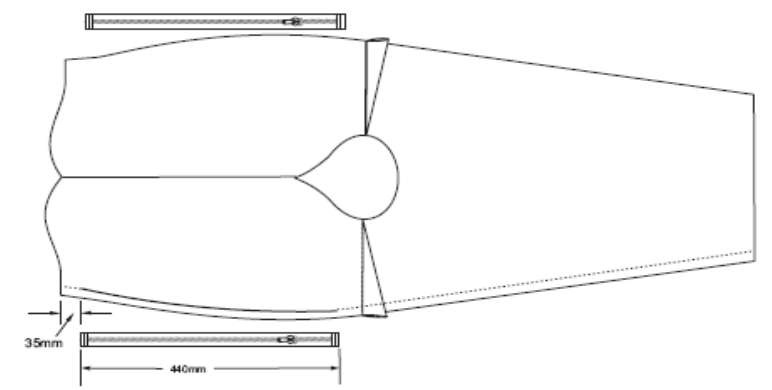

Figure A.15 – Joining the inside and outer cover fabric

3.2.6.2 Join a centre gusset (component 1.4) to the left and right lobes of the outer cover fabric, then join to the inside cover. The seam created by joining the outside edges should be centred on the end of the gusset with the taper of the gusset forming a point as it approaches the neck curve, as shown in figure A.16.

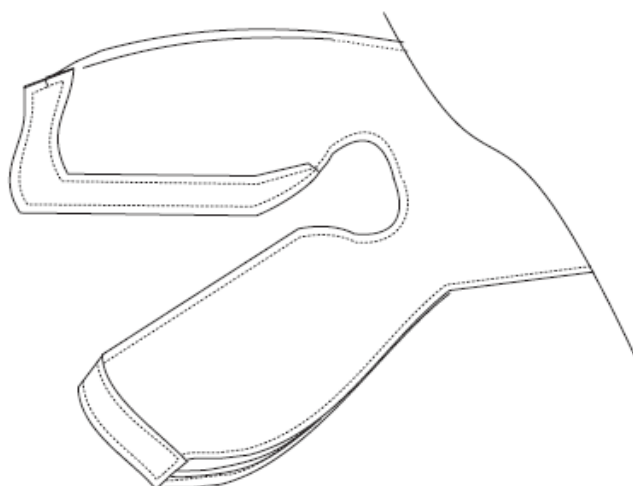

Figure A.16 – Joining the inside and outer over with the centre gusset

3.2.7 Finishing

3.2.7.1 Turn the cover right-side out. Attach the 1867 mm black waist belt webbing (component 3.3) to the back cover with three tacks, one centred on the fabric and one on each corner of the fabric. Tack the free ends of the webbing with a box-X with ends double folded. Top stitch through the inside and back outer covers, 80 mm from the foam access zipper (component 6.6).

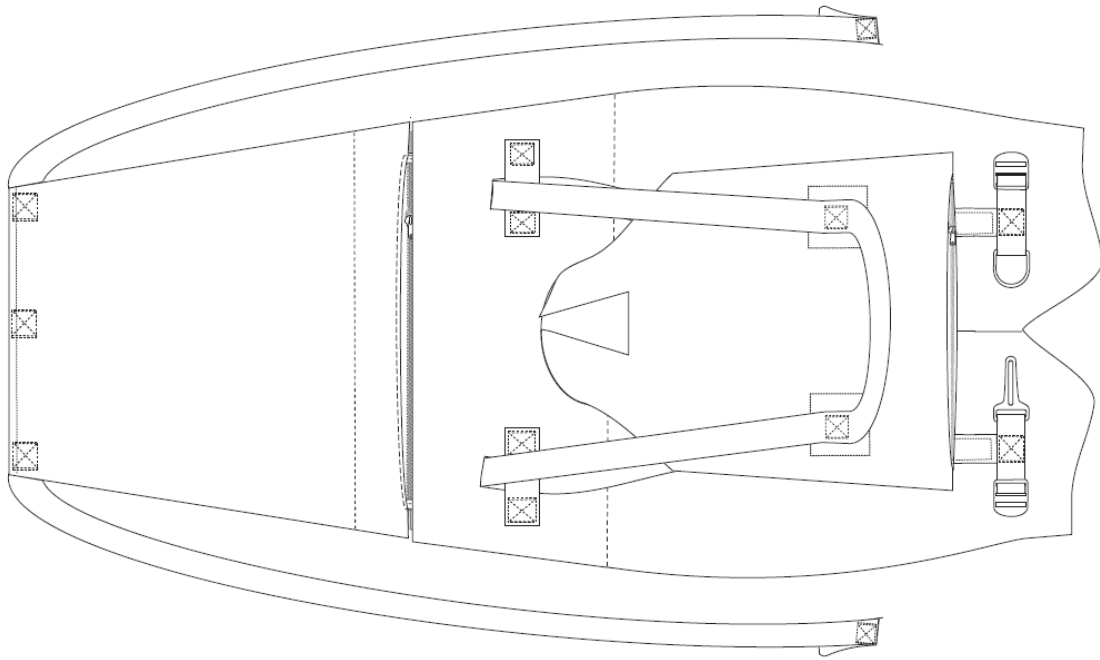

Figure A.17 – Attaching the waist belt

3.2.7.2 Lace the 1867 mm black waist belt webbing (component 3.3) through the slide adjusters (component 6.2) on each waist belt assembly.

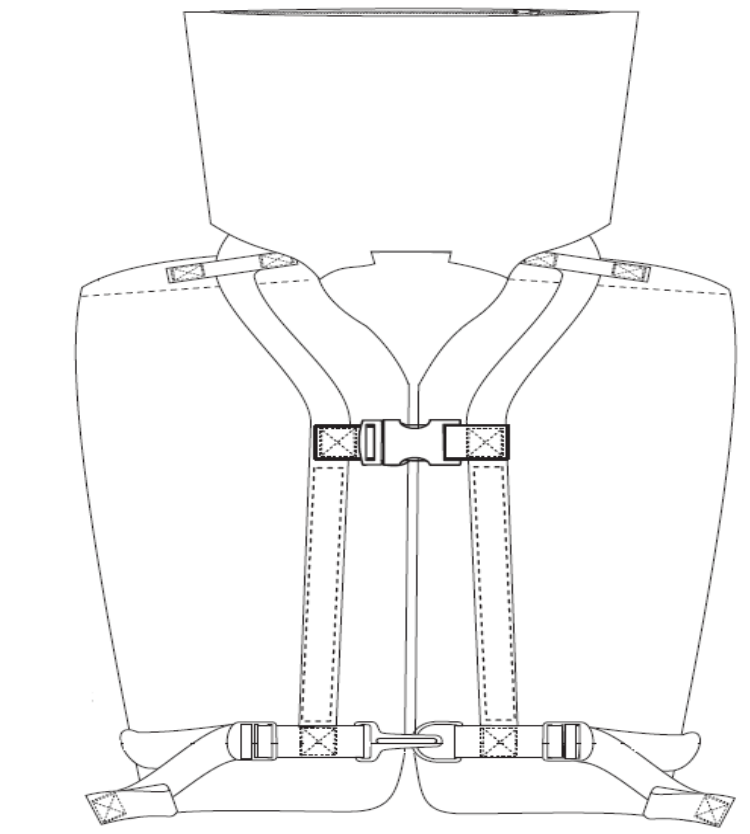
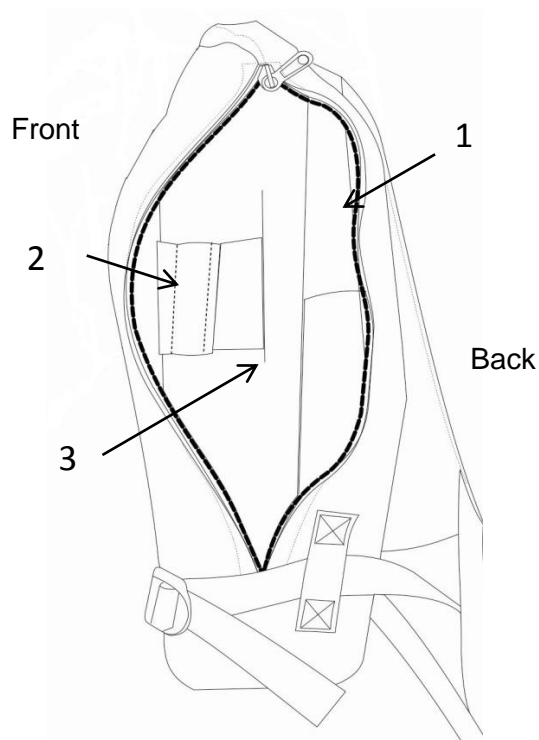

Figure A.18 – Completed RTD cover and hardware

3.3 Inserting the front foam

Slide the front foam inserts (components 2.2.1 and 2.2.2) under the interior fabric retainers for foam inserts 1 (component 1.7). Slide the interior fabric retainers for foam inserts 2 (component 1.8) through the slot in the front foam inserts (components 2.1.1 and 2.1.2). Wrap the interior fabric retainer for foam inserts around the foam insert so that the retainer passes around the front of the RTD as shown in figure A.19. Close the hook and loop fastener. Close the zipper (component 6.7).



Key

- 1 Interior fabric retainers for foam inserts 1 (component 1.7)
- 2 Interior fabric retainers for foam inserts 2 (component 1.8)
- 3 Slot (cut through foam)

Figure A.19 – Inserting the front foam

3.4 Validation

The proper assembly of the RTD should be verified according to the Guidelines developed by the Organization*.

* Refer to the *Guidelines for validating the construction of a completed adult lifejacket reference test devices (RTDs)* (MSC.1/Circ.1470).

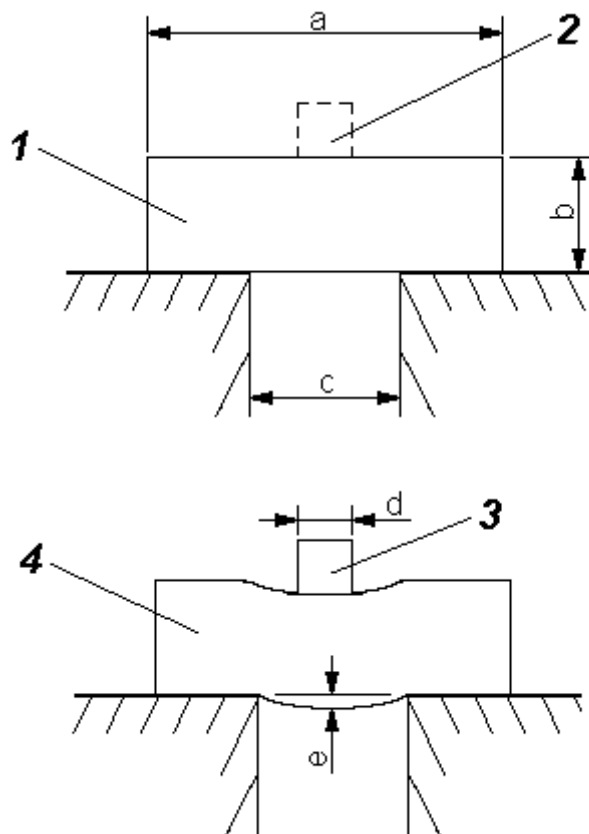

- Key:**
- 1 Foam at initial setup
 - 2 Centre load
 - 3 Load
 - 4 Foam bridge deflection after 30 s

Figure A.20 – Foam bridge deflection test

Table A.1 – Specifications for the foam bridge deflection test

Foam type	Dimension shown in figure A.20						Load mass
	a (Length) mm	(Not shown) (Width) mm	b (Thickness) mm	c (Span) mm	d (Load width) mm	e (Deflection) mm	kg
Stiff	394	110	83	300	120	< 20	8.6
Soft	394	110	45	150	30	≥ 25	0.75

Table A.2 – Parts, quantity and assembly

Component	Description	Quantity	See Figure	Construction notes
1 Cover fabric	420 denier nylon, with ravel resistant coating, orange			
1.1 Front outer cover		1	A.21	
1.2 Back outer cover		1	A.21	
1.3 Inside cover		1	A.22	
1.4 Centre gusset		2	A.23	
1.5 Collar, outer and inside cover		2	A.24	
1.6 Fabric reinforcement		4	A.25 A.33	Attach to inside of collar cover, as attachment 1, for reinforcement at webbing attachment (see figure A.33).
1.7 Interior fabric retainers for foam inserts 1		2	A.26 A.1	Attach to inside of front cover, as attachment 3, stitch to cover at each side to form a foam retainer for inside front foam insert components 2.2.1 and 2.2.2 (see figure A.1).
1.8 Interior fabric retainers for foam inserts 2		2	A.26 A.3	Attach hoop and loop fasteners to the ends and stitch at centre to the inside of front cover, as attachment 4, to form a foam retainer for front foam insert components 2.1.1 and 2.1.2 (see figure A.3).
2 Foam				
2.1 Stiff	See tables A.1 and A.3			
2.1.1 Front foam insert, right side	81 mm thick	1	A.27	
2.1.2 Front foam insert, left side	81 mm thick	1	A.27	
2.1.3 Collar foam insert	56 mm thick	1	A.29	
2.2 Soft	See tables A.1 and A.3			
2.2.1 Inside front foam insert, right side	46 mm thick	1	A.28	
2.2.2 Inside front foam insert, left side	46 mm thick	1	A.28	
2.2.3 Back foam insert	25 mm thick	1	A.30	

Table A.2 (continued)

Component	Description	Quantity	See Figure	Construction notes
3	Webbing			
	25 mm, polypropylene, with easy adjustment and no significant slippage when used with the specified hardware.			
3.1	Chest strap	2	A.11 A.31	On left side of front cover, attach webbing with male buckle. On right side of front cover attach webbing with female buckle. The free ends of the chest strap are folded under the yellow webbing (collar attachment webbing), with reinforcing fabric (see figure A.25) on inside of cover fabric. A box-x stitch is used to attach the chest strap to the front cover.
3.2	Waist belt	2	A.12 A.31	On left side attach waist belt with slide and buckle clip waist belt. On right side attach bottom belt with D-ring and slide.
3.3	Waist belt	1	A.31 A.32 A.17	Form 40 mm tab on each end. Attach to back cover using three box-x stitches (after front and back covers are assembled).
3.4	Belt-loop on front cover	2	A.31 A.8	Attach webbing to front outer cover and form a belt-loop (one on each side) by two sets of double bar tack stitches.
3.5	Belt-loop on inside cover	2	A.32 A.4	Attach webbing to inside cover and form a belt-loop (one on each side) by two box-x stitches.
3.6	Collar attachment	1	A.14 A.6 A.31 A.33	Attach webbing to collar and reinforcing fabric, in two places using box-x stitch.
4	Hook and loop fastener	2	A.2 A.26	Hook and loop fasteners are attached to the ends of interior fabric retainer for foam insert.
5	Thread	AR		
6	Hardware			
6.1	Buckle	1		Chest strap
6.2	Slide	2		Waist belt
6.3	Snap hook	1		Waist belt
6.4	D-ring	2		Waist belt
6.5	Zipper	1	A.6 A.33	Foam access for collar cover
6.6	Zipper	1	A.9 A.31	Foam access for back cover
6.7	Zipper	2	A.15 A.31 A.32	Foam access for front cover

Table A.2 – Foam insert specifications

Values in Newton (N)

	Front right	Front left	Inside front right	Inside front left	Back	Collar
Foam type ^a	Stiff	Stiff	Soft	Soft	Soft	Stiff
Buoyancy ^b	34 ± 1,1	34 ± 1,1	17,75 ± 0,65	17,75 ± 0,65	18,5 ± 0,7	28 ± 0,8
<p>^a The buoyancy of most foams will change over time with the greatest change occurring in the first several months after manufacture. The exact kind of foam selected will need to be evaluated to determine the amount of additional buoyancy needed at the time of manufacture to maintain the values specified.</p> <p>^b Buoyancy distribution: 69% front ± 1.5 percentage points.</p>						

Table A.3 – List of dimensions shown in figures A.21 to A.33

Dimensions in millimetres

Letter	Figure											
	A.21	A.22	A.23	A.24	A.25 A.26	A.27	A.28	A.29	A.30	A.31	A.32	A.33
<i>a</i>	66	298	23	308	73	198	76	20	188	120	138	19
<i>b</i>	298	100	497	75	73	46	46	56	274	18	18	155
<i>c</i>	427	1106	586	10	130	76	394	51	414	35	35	53
<i>d</i>	430	199	102	288	205	84	38	216	343	55	295	25
<i>e</i>	423	398		342	72	76	51	229	147	95	55	45
<i>f</i>	141	597		396	470	157	165	259	223	320		
<i>g</i>	100	1124		65		394		45		90		
<i>R</i>							51	70				
<i>h</i>	705	141				46				40		
<i>i</i>	199					8				55		
<i>j</i>	398					20				225		
<i>k</i>	197					20				80		
<i>l</i>	723					76						
<i>m</i>	176					46						
<i>n</i>	245					38						
<i>o</i>						165						
<i>p</i>						25						

Table A.5 – List of dimensions shown in figures A.35 and A.36

Dimensions in millimetres

Figure	Dimension											
	<i>a</i>	<i>b</i>	<i>c</i>	<i>d</i>	<i>e</i>	<i>f</i>	<i>g</i>	<i>h</i>	<i>i</i>	<i>j</i>	<i>k</i>	<i>l</i>
A.35	450	530	980 ^a	90	60	340	20	310	70	50	60	260
A.36	260	340	230	120	215	210	60	290				
	<i>m</i>	<i>n</i>	<i>o</i>	<i>p</i>	<i>q</i>	<i>r</i>						
A.35	240	270	130	80	70	30						
A.36												

^a Dimension *c* in figure A.35 = dimensions *a* + *b* (i.e. dart closed).

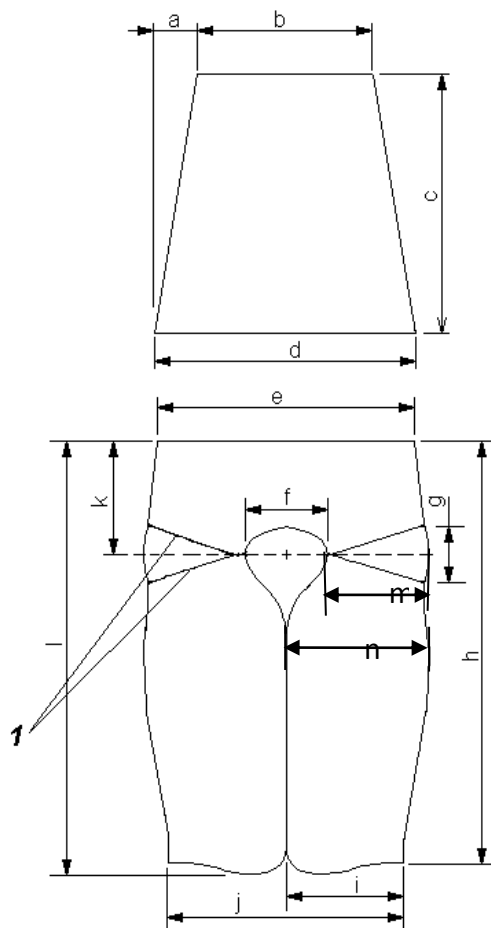

Key:

1 Dart

Figure A.11 – Outer cover, front and back sections

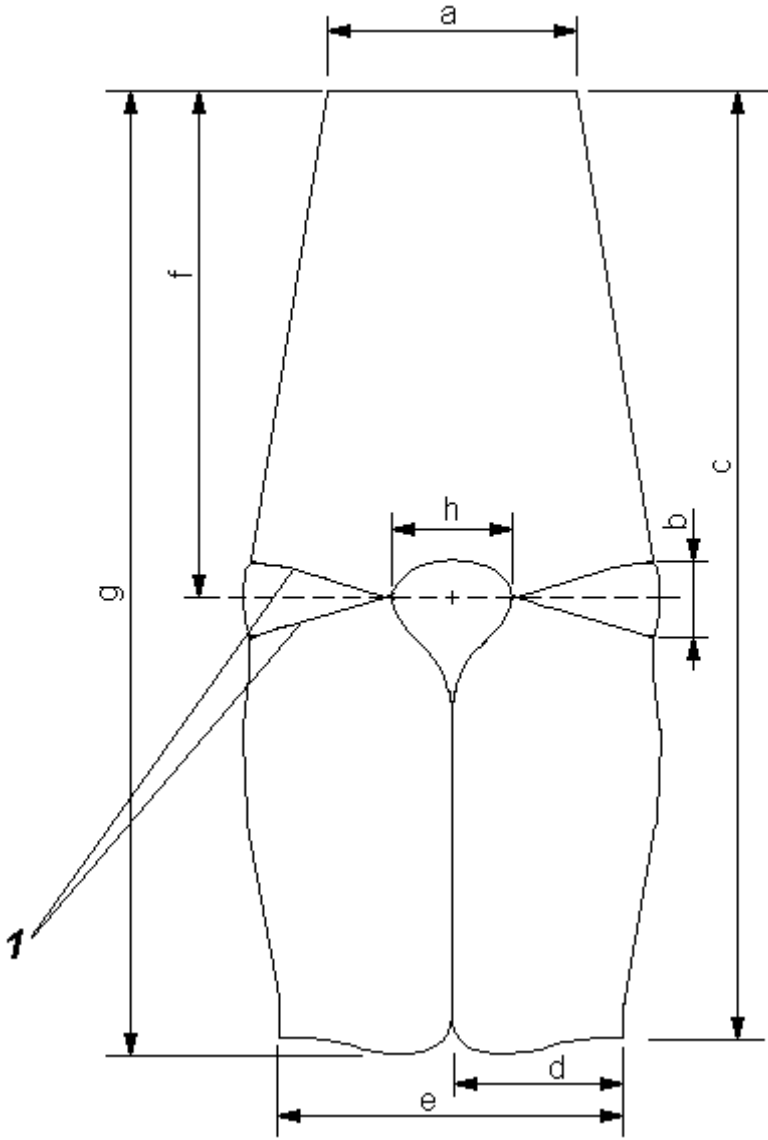

Key:
1 Dart

Figure A.22 – Inside cover

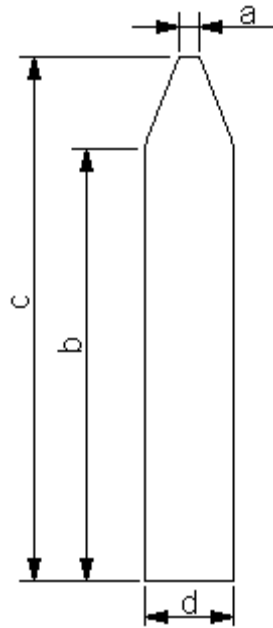

Figure A.23 – Centre gusset

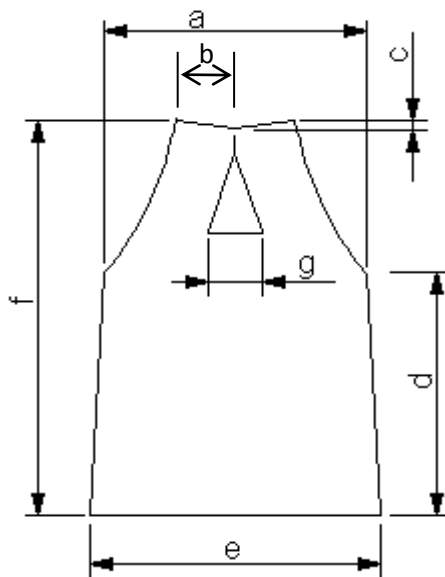

Figure A.24 – Outer and inside cover, collar

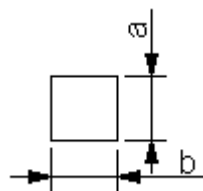
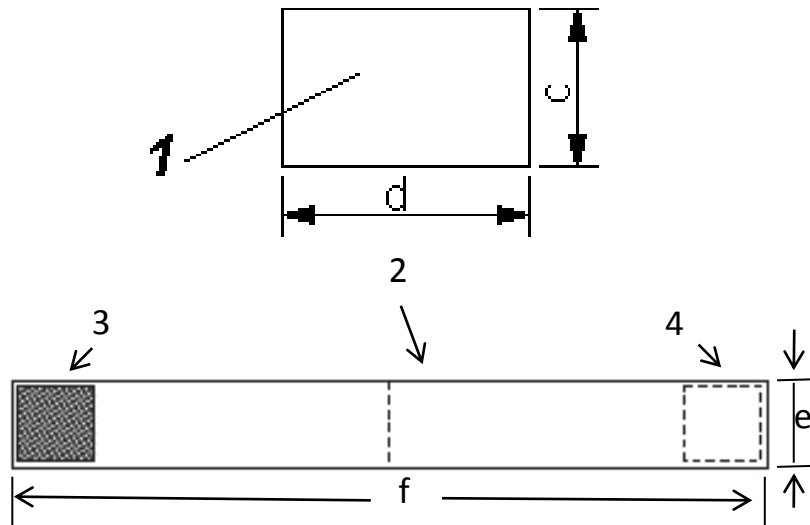
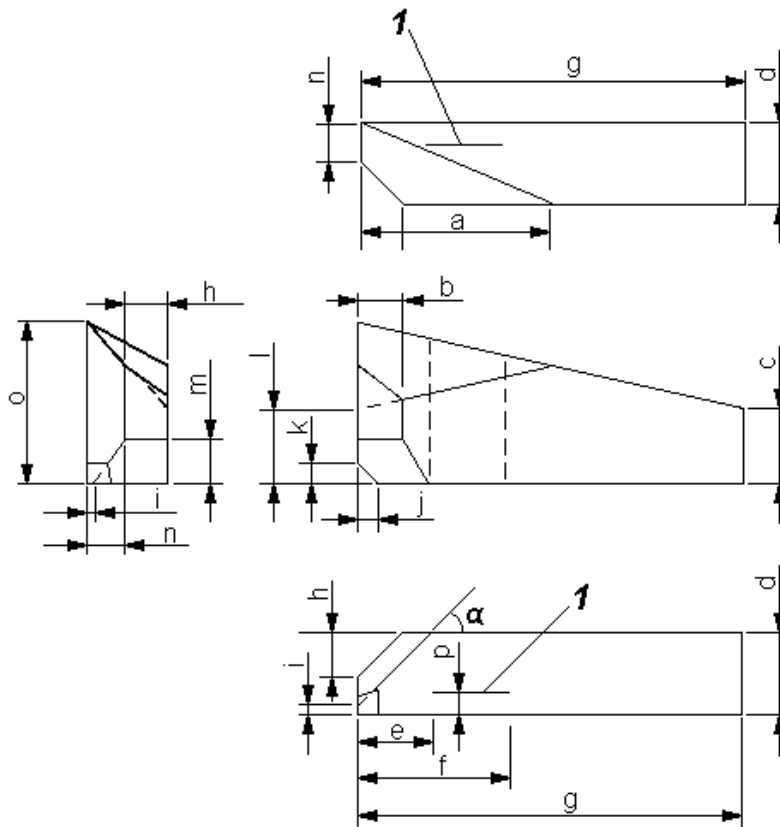

Figure A.25 – Fabric reinforcement



- Key:**
- 1 Fabric retainer for the front soft foam insert
 - 2 Fabric retainer for the soft and stiff foam inserts
 - 3 Hook and loop fastener (hook portion)
 - 4 Hook and loop fastener (loop portion)

Figure A.26 – Interior foam retainer



- Key:**
- 1 Slot (cut through foam insert)
 - α 45°

Figure A.27 – Front foam insert

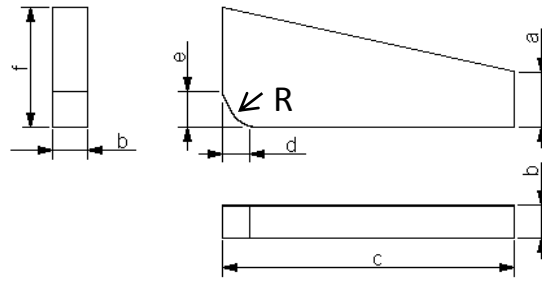
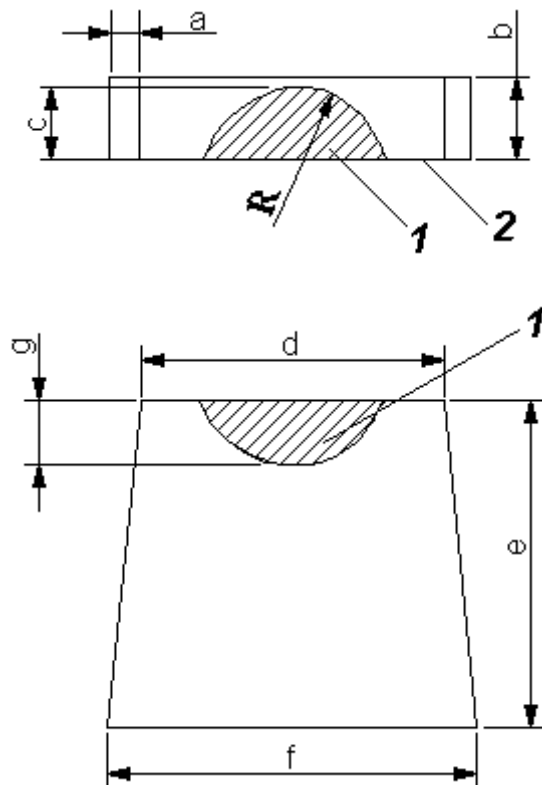

Figure A.28 – Inside front foam insert



- Key:**
1 Skive
2 Side towards body

Figure A.29 – Collar foam insert

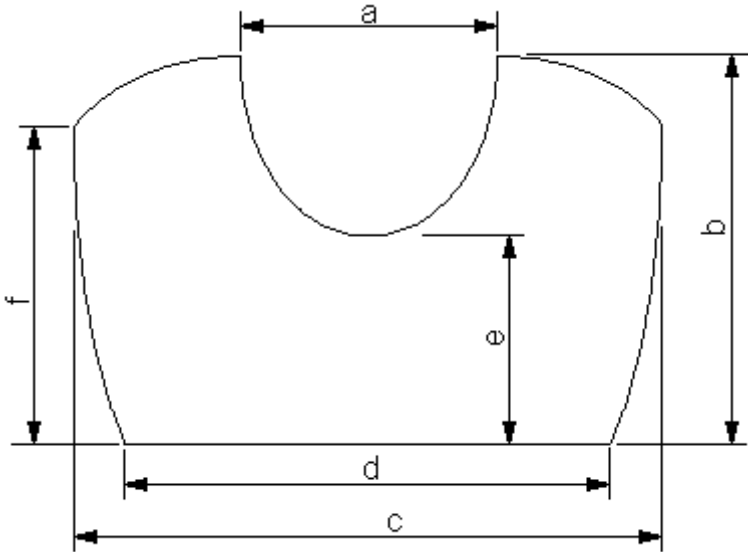
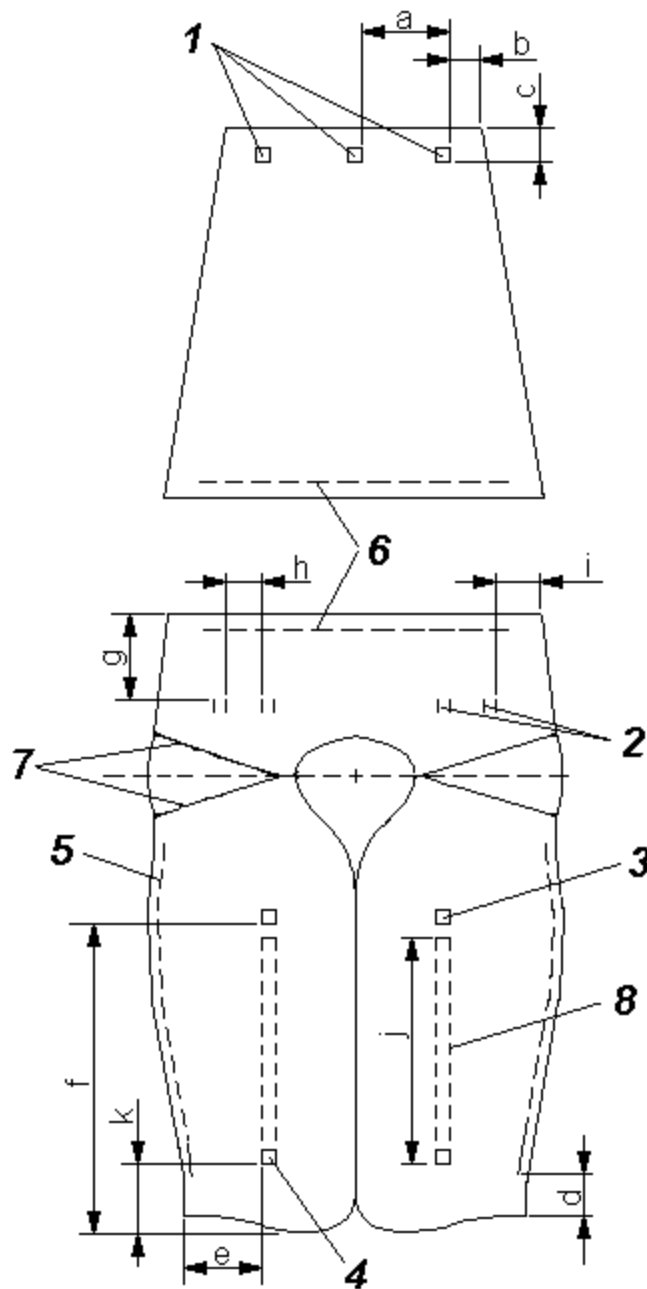

Figure A.30 – Back foam insert



Key:

- 1 Waist belt (1,867 mm) attachment to outside of back cover
- 2 Belt loop webbing (76 mm) attachment to outside of front cover
- 3 Chest strap (webbing (127 mm)) attachment to outside of front cover
- 4 Waist belt (203 mm) attachment to outside of front cover
- 5 Zipper (440 mm) attachment to front
- 6 Zipper (370 mm) attachment to the front and back covers
- 7 Dart
- 8 Collar webbing (1,384 mm) attachment to outside of front cover

**Figure A.31 – Attachments to front and back cover
(dimensions on pattern, before sewing)**

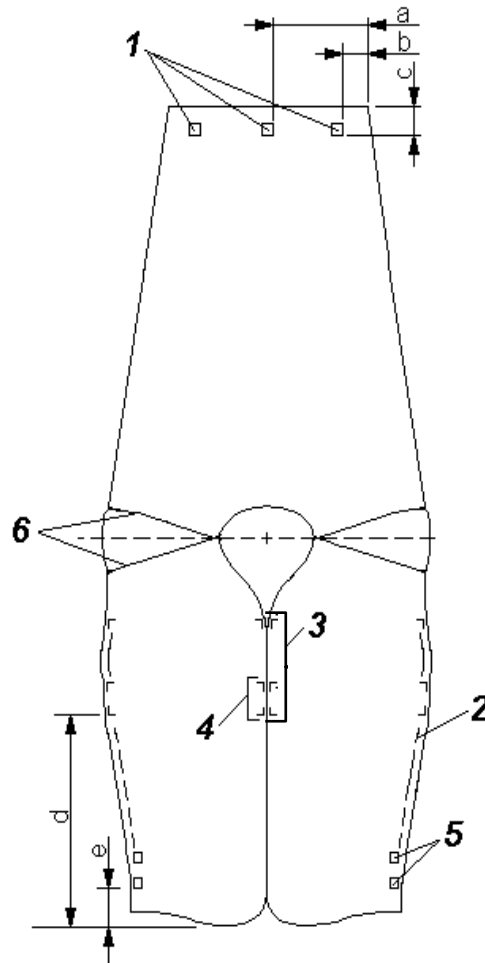

Key:

- 1 Waist belt (1,867 mm) attachment to outside of back cover and inside cover (see figure A.31)
- 2 Zipper (440 mm) attachment
- 3 Interior fabric retainer attachment to inside front cover
- 4 Interior fabric retainer attachment to centre of inside front cover
- 5 Belt loop webbing (89 mm) attachment to outside of cover
- 6 Dart

**Figure A.32 – Attachments to inside cover
(dimensions on pattern, before sewing)**

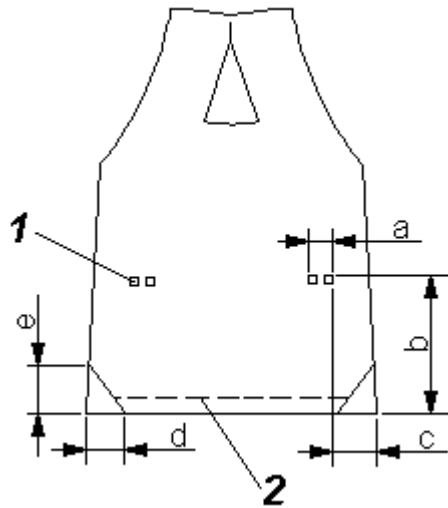

Key:

- 1 Collar webbing (1,384 mm) attachment on the outside of the inner cover with reinforcement fabric inside
- 2 Zipper (280 mm) attachment to the outer and inner covers

**Figure A.33 – Attachments to outer and inside collar cover
(dimensions on pattern, before sewing)**

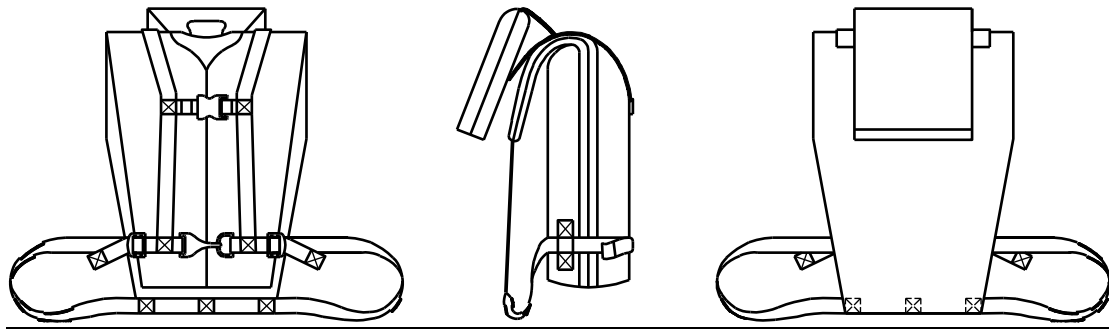
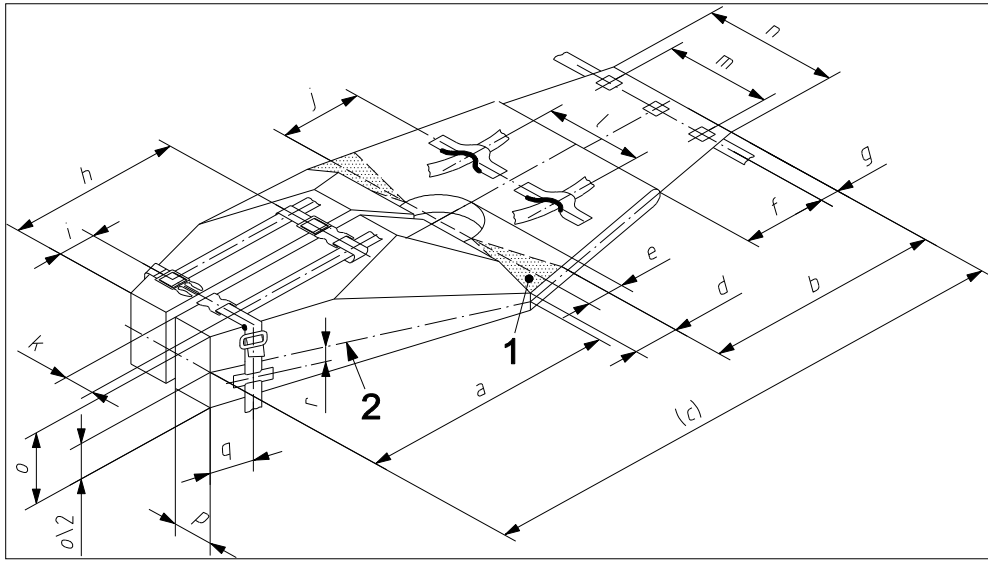
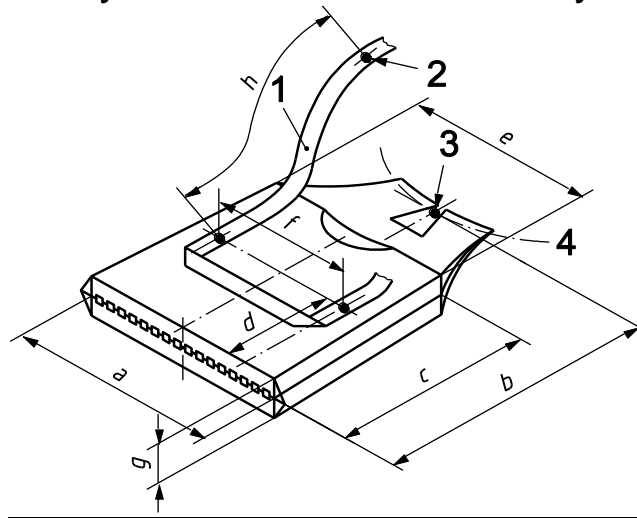

Figure A.34 – Assembly views of finished RTD



- Key:**
- 1 Dart at shoulder seam; shown spread out
 - 2 Seam line and side zipper location

Figure A.35 – Assembly dimensions of finished RTD body with collar removed



- Key:**
- 1 Collar attachment webbing
 - 2 Nearest point of attachment to chest of vest
 - 3 Centre of neck seam on vest
 - 4 Assembly seam in neck of vest

Note: *h* is measured along the webbing to the nearest point of attachment.

Figure A.36 – Assembly dimensions of finished RTD collar"
